

# Basel



**adea**

# Basel

Design Mats Broberg & Johan Ridderstråle

The working title for the Basel sofa was ‘house wine’. The aim was to design a sofa without grand gestures but with a more refined sense of shape, proportions and comfort that suits a wide range of interior styles”, say the designers.

Just like the house wine at a good restaurant – a carefully selected bottle of good quality that goes well with all kinds of food at a good price. The Basel sofa, with its low-key and sophisticated style, is a sure thing together with most furnishings and in all types of spaces. The overall proportions and detailing in Basel’s upholstery and legs have been fine-tuned by skilled craftsmanship and experienced architects to form the ultimate standard with an understated elegance.



Pictures: Basel 220 & ottoman - Baltimore 04

# Measurements

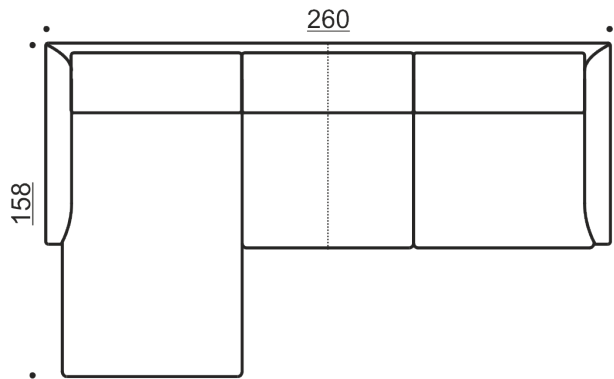
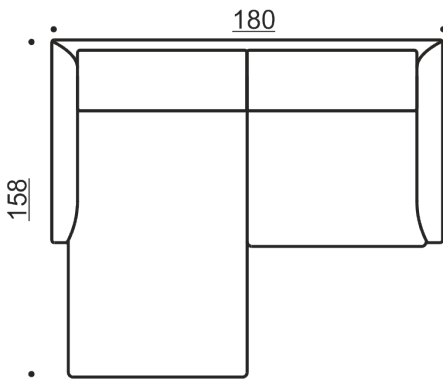
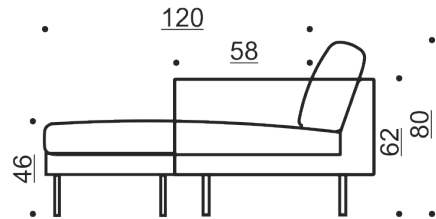
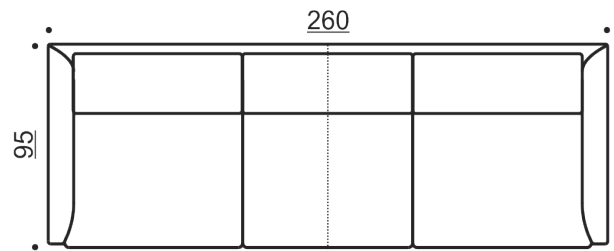
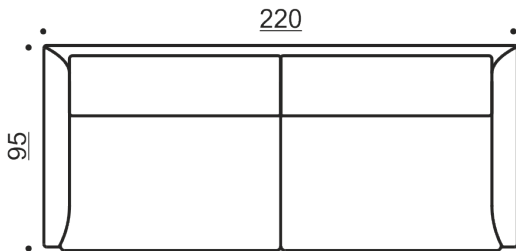
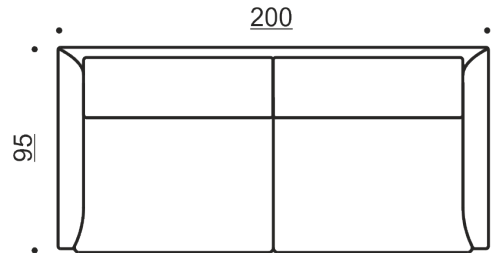
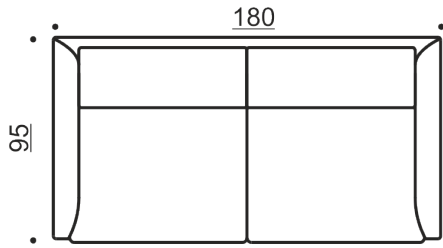
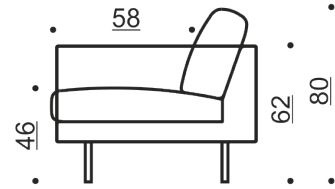

The orientation of the divan can be easily changed.

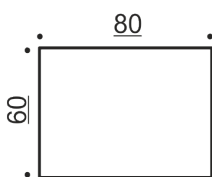

All measurements +/- 3 cm

Upholstery: removable fabric upholstery, fixed leather upholstery

# adea



[www.adea.fi](http://www.adea.fi)  
[@adeacollection](https://www.instagram.com/adeacollection)

[info@adea.fi](mailto:info@adea.fi)  
+358 20 7288 620

